

PRODUCT MANUAL

L30B / L35B

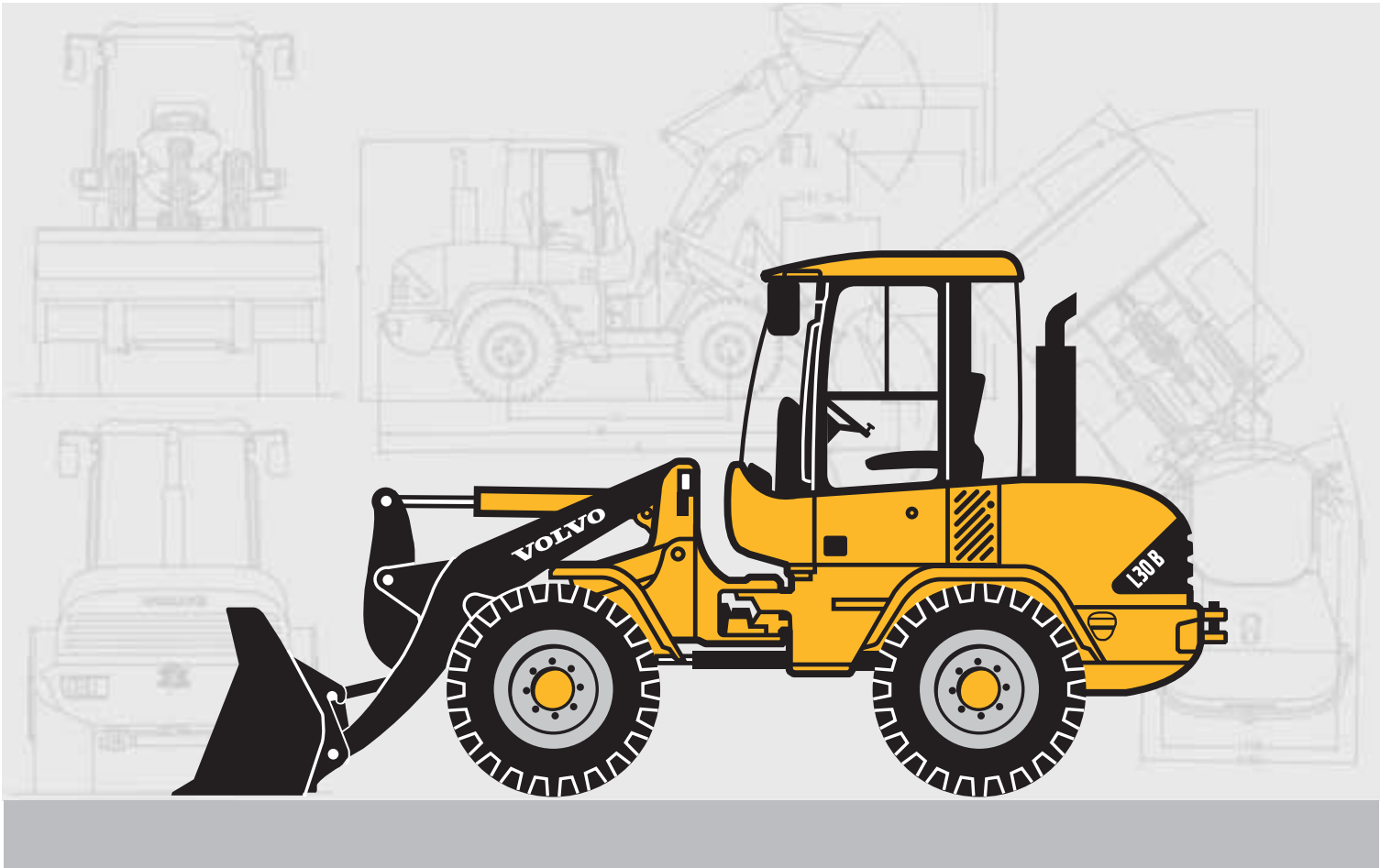

VOLVO

Table of Contents

Introduction	from 02 to 08
Sturdiness	from 09 to 14
Quality.....	from 15 to 20
Performance	from 21 to 28
Comfort.....	from 29 to 36
Safety	from 37 to 46
Service	from 47 to 54
Options/Versatility	from 55 to 63

Introduction



Product Features

The L30B and L35B Volvo Compact Wheel Loaders distinguish themselves by their innovative design, optimum driving comfort, excellent performance and enormous versatility. With a Volvo Compact Wheel Loader you have the ideal machine for every application.

WELL PROVEN WHEEL LOADER ENGINEERING

- Compact design for manoeuvrability and speed
- Transverse mounted engine with directly flanged pumps for hydrostatic driving, working and steering hydraulics for easy service
- Well balanced components - effective working
- Easy access to service points and long service intervals
- Wide range of attachments available

INNOVATION

- ESIS: Electronic Service and Information System, makes maintenance and service an easy job.
- Modern manufacturing methods, new materials for cab and covers turn Volvo wheel loaders into comfortable, reliable and save machines.
- Optimized strength and stability achieved by new computer assisted design and calculation methods. Further advantages: good manoeuvrability, long-life expectancy.

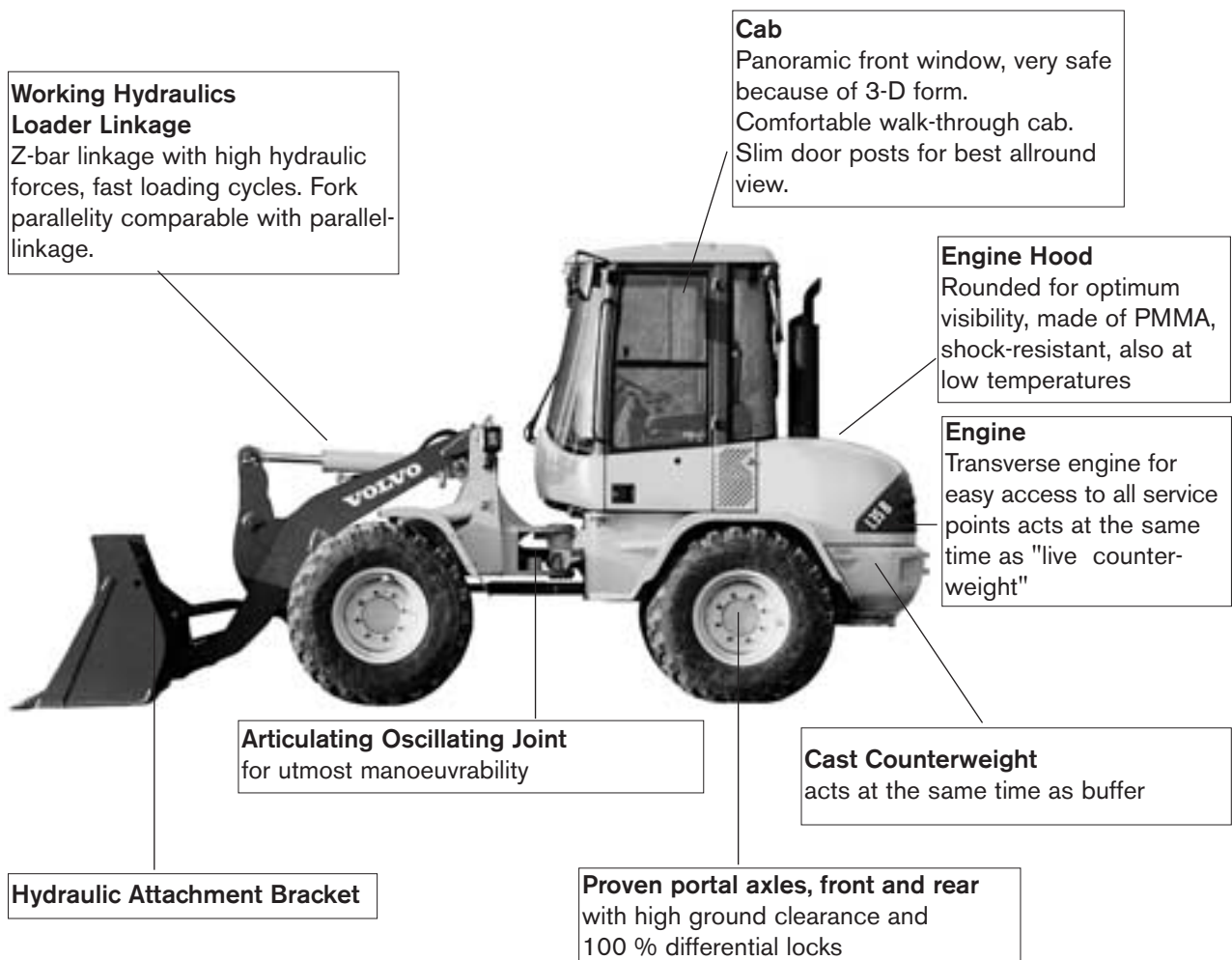

Main Data at a Glance

DIMENSIONS • Z-BAR LINKAGE

L30B with Z-bar linkage, Z-attach. bracket and 12.5-20 IND. SG tires	
B	4390 mm 14' 5"
C	2150 mm 7' 1"
D	465 mm 1' 6"
F	2690 mm 8' 10"
G	870 mm 2' 10"
J	3000 mm 9' 10"
K	3200 mm 10' 6"
O	70 °
P	45 °
R	50 °
S	140 °
U	200 mm 0' 8"
X	1436 mm 4' 9"
Y	1758 mm 5' 9"
Z	2900 mm 9' 6"
a ₂	3880 mm 12' 9"
a ₃	2070 mm 6' 9"
a ₄	±40 °

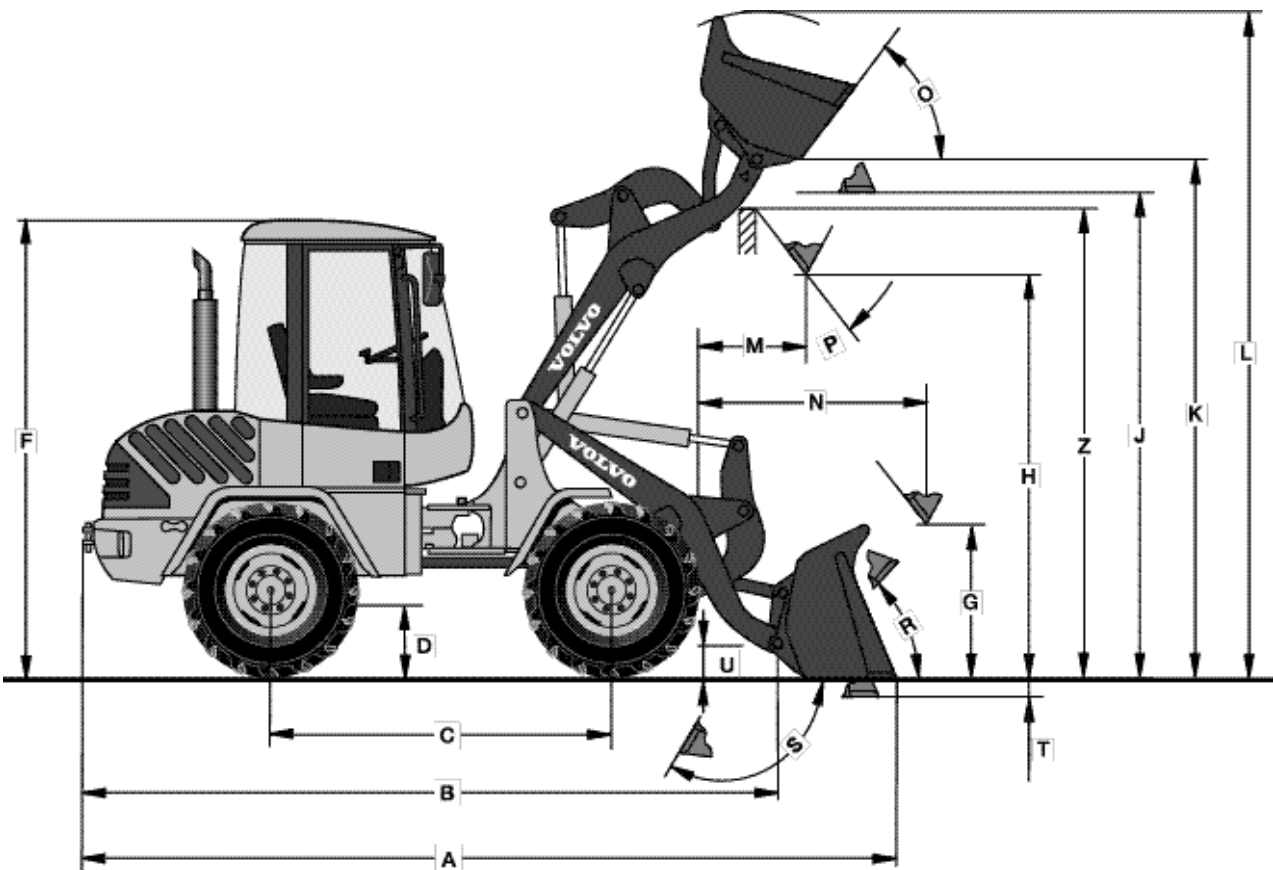
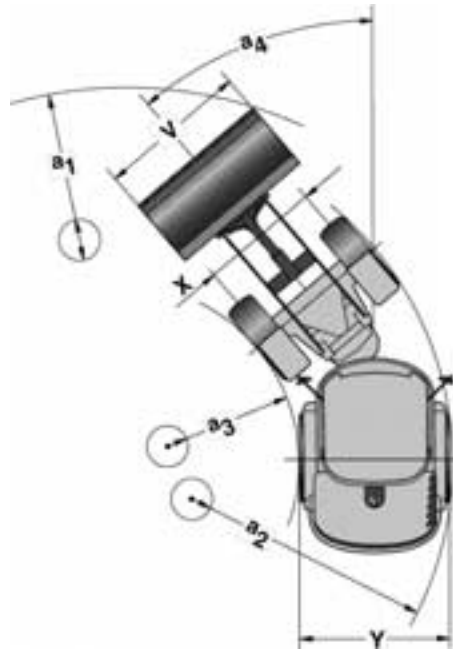

Main Data at a Glance

DIMENSIONS • Z-BAR LINKAGE

L35B with Z-bar linkage,
Z-attachment bracket
and 14.5 - 20 tires

B	4505 mm	14' 9"
C	2150 mm	7' 1"
D	445 mm	1' 6"
F	2710 mm	8' 11"
G	900 mm	2' 11"
J	3115 mm	10' 3"
K	3315 mm	10' 11"
O	66 °	
P	45 °	
R	50 °	
S	135 °	
U	200 mm	0' 8"
X	1552 mm	5' 0"
Y	1905 mm	6' 4"
Z	3020 mm	9' 11"
a ₂	3960 mm	13' 0"
a ₃	1980 mm	6' 6"
a ₄	±40 °	

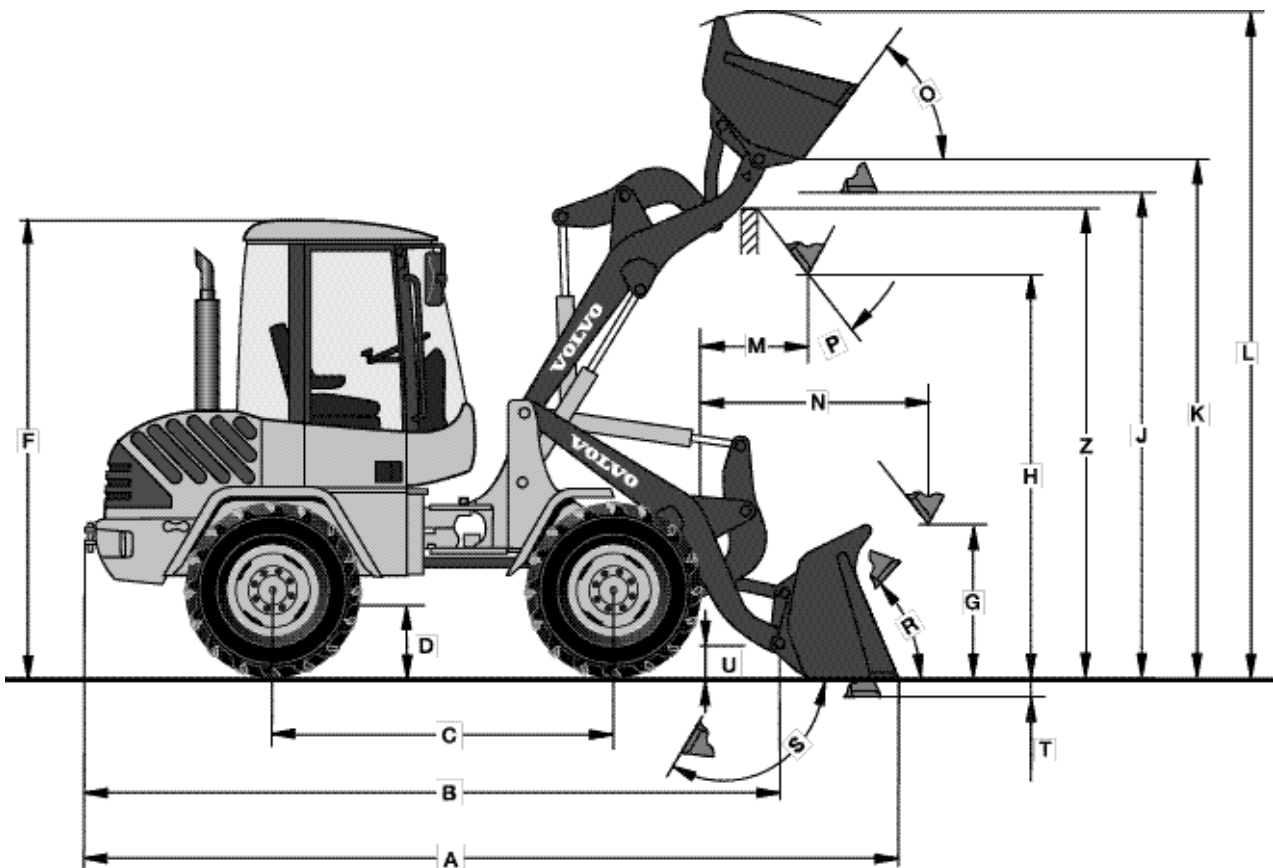
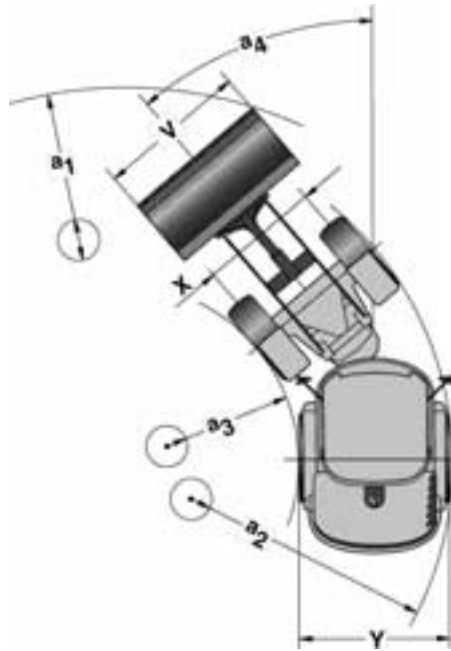

Main Data at a Glance

The L30B is the star in the 60HP category. It is a real all-rounder, at home in many applications. With its optimised Z-kinematics it is designed for both bucket and forklift applications. The L30B is available in 2 speed versions: there is a standard 12.4 mph and a high-speed version with 19 mph.

Model	Imperial		Metric	
Volvo L30B	Z-bar		Z-bar	
Type of Linkage	Z-bar		Z-bar	
Engine Power	kW/hp	73/100	kW/hp	43/58
Standard Tires		15.5-20		12.5-20
Operating Weight	lb	11,003	t	4,990
Speed	mph	12.5/19	km/hp	20/30
Bucket Capacity SAE	yd ³	1.0	m ³	0.8
Dump Height	ft in	8'4"	mm	2520
Reach at max. Height (45°)	ft in	2'4"	mm	705
Tipping Load, full Turn	lb	7385	kg	3350
Lifting Capacity	lbf	9442	kN	42.0
Breakout Force	lbf	11,578	kN	51.5
Loading Fork				
Payload (80 %)	lb	4519	kg	2050



Main Data at a Glance

The L35B is the star in the 60HP category. It is a real all-rounder, at home in many applications. With its optimised Z-kinematics it is designed for both bucket and forklift applications. The L30B is available in 2 speed versions: there is a standard 12.4 mph and a high-speed version with 19 mph.

Model	Imperial		Metric	
Volvo L35B	Z-bar		Z-bar	
Type of Linkage	Z-bar		Z-bar	
Engine Power	kW/hp	52/70	kW/hp	52/70
Standard Tires		14.5-20		14.5-20
Operating Weight	lb	12,790	t	5.8
Speed	mph	12.5/19	km/hp	20/30
Bucket Capacity SAE	yd ³	1.4	m ³	1.05
Dump Height	ft in	8'8"	mm	2640
Reach at max. Height (45°)	ft in	2'6"	mm	750
Tipping Load, full Turn	lb	8708	kg	3950
Lifting Capacity	lbf	12,365	kN	55.0
Breakout Force	lbf	12,365	kN	55.0
Loading Fork				
Payload (80 %)	lb	5400	kg	2450



Important Improvements with the Introduction of the New B-Series

Comparing main differences to the former series

- larger standard bucket capacities
- improved tipping loads
- reduction of internal and external noise level
- cooling system adjustable to the conditions of application environment
- optimized climatization performance optional



Sturdiness



Maximum Protection

With its new B-series Volvo continues to build on its proven frame concept with an articulating oscillating joint. The round rear with a wrap-around counter-weight protects the machine from unintentional damage.

Cabin

The cabin complies with the international ISO ROPS/FOPS requirements. Open cabin doors are retained within the contour of the machine to prevent accidents and damage. Excellent over-all view contributes to the passive security of all VOLVO Compact Wheel Loaders.

Working-Hydraulic / Linkage

The hydraulic hoses for the attachment carrier and auxiliary hydraulic circuits are built into the lift arm to grant maximum protection. All bearings are sealed; to ensure long lifetime the bolts are gas-carburized.

Engine Hood

The important maintenance points such as oil-filter, air-filter, oil-inlet, fuel-inlet, etc. are located inside the lockable engine compartment.

Engine

The watercooled engine fulfills all requirements for easy maintenance and long maintenance-intervals. The fuel-injection system of the Deutz engine is protected by a fuel filter combined with a water separator.

Articulating Oscillating Joint

The hydraulic hoses of the pilot control system run through the joint to the main control valve in order to avoid damage.

Cast Counterweight

The wrap-around counterweight fulfills the function of a bumper. Protruding the machine's contour it is an efficient protection for the machine's body and engine compartment. The angle of departure keeps the machine from touching ground.

Hydraulic Attachment Bracket

The tried-and-tested attachment bracket design attains durability because of the large, sealed bearings and a significant lubricant supply.

Axles

Proven Design Portal axles. High ground-clearance grants impact protection from below, contributing to the passive security of the machine.



Tried and Tested Frame Design

Computer-aided construction methods were used to design the frame parts so that dangerous high tensions on strained parts of the machine could be avoided. As a result the components can withstand extremely high loads. The heavy-duty central articulating oscillating joint of cast metal provides the loader with the necessary mobility. An articulation angle of approximately 40° and an oscillation angle of approximately 10° do not only ensure maximum agility, but also provide an excellent power distribution on all four wheels. The robot-welded front and rear frame parts are manufactured with state-of-the-art production methods. The rear fenders and the steps for access are integrated into the frame.

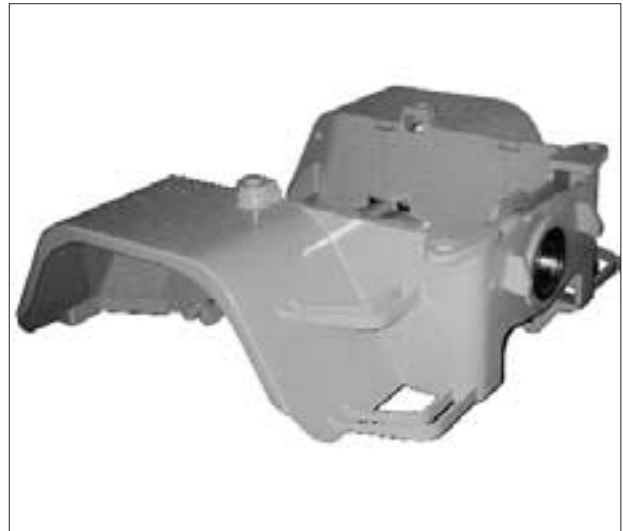

Compact Shock-Protected Rear Section

The rear sections of the Volvo Compact Wheel Loaders L30B-L35B are ideally protected against damage. Both on the rear and on the sides the cast counter-weight protrudes from the outline of the machine. Its bevelled lower side allows it to be used on slopes with an extremely high gradient, which is quite an advantage when working on rough terrain. The closed bottom plate protects the engine compartment from objects such as big branches or large rocks penetrating from the ground. The front and rear fenders are made of steel, which makes them ideally suited for the heavy work on construction sites. Together with the counter-weight they provide all-round protection for the total machine. An additional feature is that the doors lock open within the contour of the fenders. A further feature worth mentioning is the engine hood from PMMA, an extremely impact-resistant plastic, which can even withstand severe blows.



Well-Protected Working Equipment

The hydraulic hoses of the pilot control system run through the articulating oscillating joint to the main control valve, this avoids damage from exterior influences. The hydraulic hoses for the quick coupler or the additional hydraulic circuits are housed in the lift arm for optimum protection.

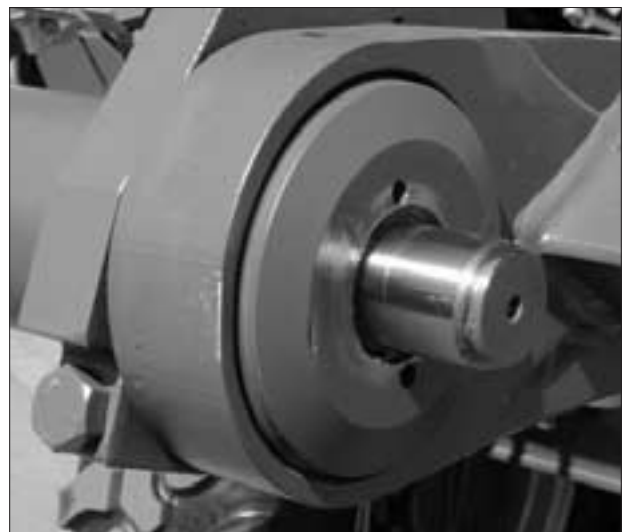

Well-Protected Working Equipment

The hydraulic hoses of the pilot control system run through the articulating oscillating joint to the main control valve to avoid damage from exterior influences. The hydraulic hoses for the quick coupler or the additional hydraulic circuits are housed in the lift arm for optimum protection.

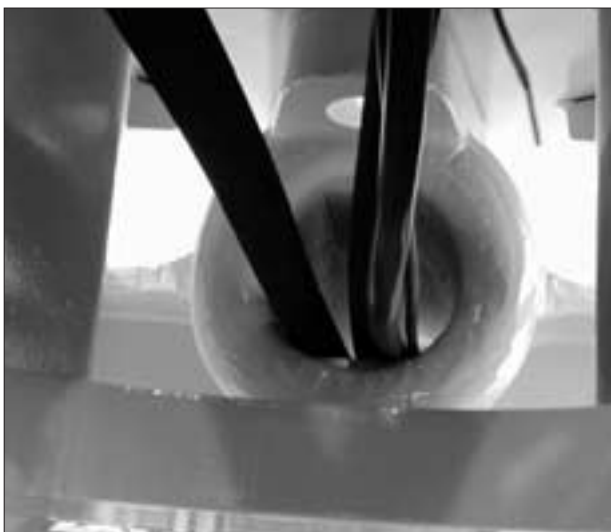
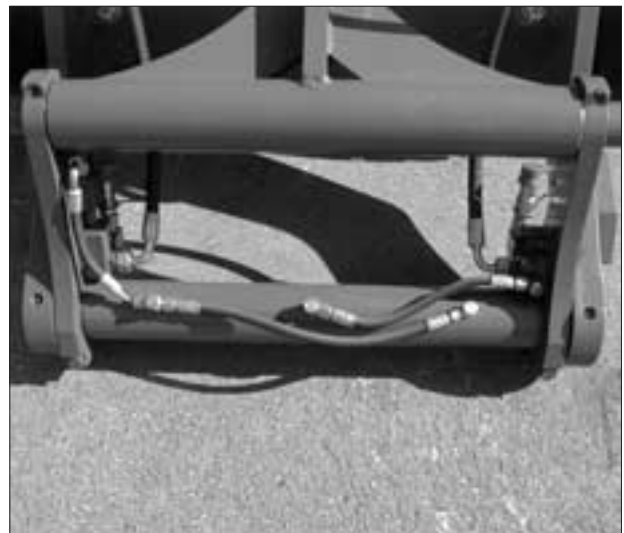

Quality



High-Quality Components from Well-Known Manufacturers

Volvo Compact Wheel Loaders are exclusively powered by Deutz engines. The L30B and the L35B has the 1011 engine series which has already proved itself as a high-performance, low-emission and silent engine for construction equipment for many years. The 1011 has an integrated "double" cooling system. The cylinder head is air-cooled; the engine block is cooled by the engine oil. Advantage: the same oil for cooling and lubrication. No corrosion and cavitation inside the engine.

	L30B	L35B
Engine Type	BF4L 1011FT	BF4L 1011F
Fuel consumption, depending on application		
	gpm	gpm
high	0,026	0,031
medium	0,020	0,024
low	0,013	0,018
	l/h	l/h
high	6,0	7,0
medium	4,5	5,5
low	3,0	4,0
Exhaust-Emissions (g/kWh)		
Smoke units	0,25	0,30
CO	2,0	1,5
NOx	8,0	8,2
HC	1,0	0,85
Inclination to all sides		
	30°	30°



High-Quality Components from Well-Known Manufacturers

As expected the drivetrain of the Volvo Compact Wheel Loaders is composed of proven components. The hydrostatic transmission can be fully shifted under load, both when changing direction and in all ranges. The hydraulic motors - one or two - directly transmit the power to the portal axles manufactured by ZF. The driving system, the steering and the working hydraulics are cooled by a central, thermostatically controlled cooling system with a hydraulically powered fan. The operating temperatures have been greatly improved in comparison to the machine's predecessors. The total drive system and the diesel engine have been designed to run for maximum operating hours provided that the equipment is properly maintained.

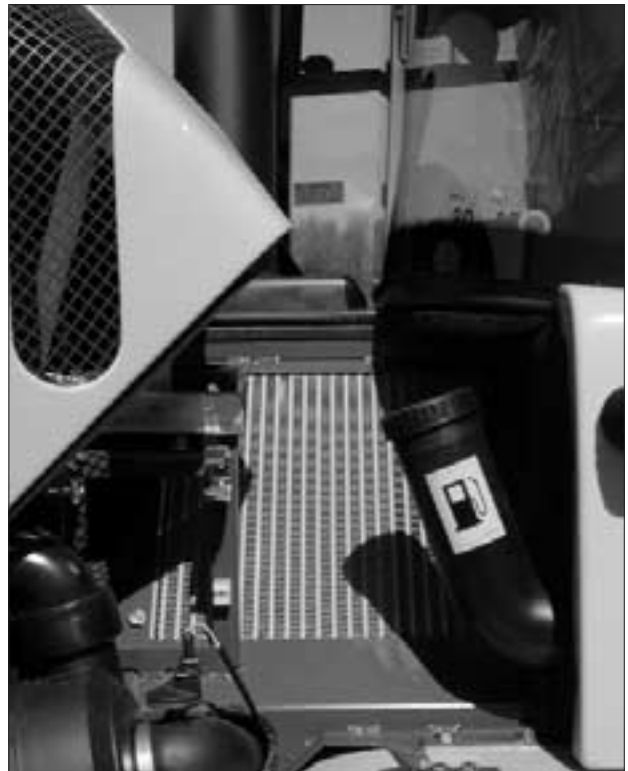

Electrical System

The electronic service and information system, ESIS, constantly provides the driver with important information on his machine, allowing him a continuous control of the main functions such as the fuel and temperature levels for the engine and the hydraulics. The key component of the system is the central computer. It is built on a carefully arranged circuit board placed well protected, yet easily accessible in the cabin. All electro-hydraulic valves in the machine are controlled by electronic, and therefore short-circuit proof, components, which do not need additional safeties. In addition, electronic components are not subject to wear. Other sources of energy, such as the lighting, are fused by standard safeties which are also used in the automotive industry. The relays on the PCB are designed for over 500,000 switching actions. In addition, various cables and wires have been marked alphanumerically in accordance with the Volvo standards to facilitate possible troubleshooting.

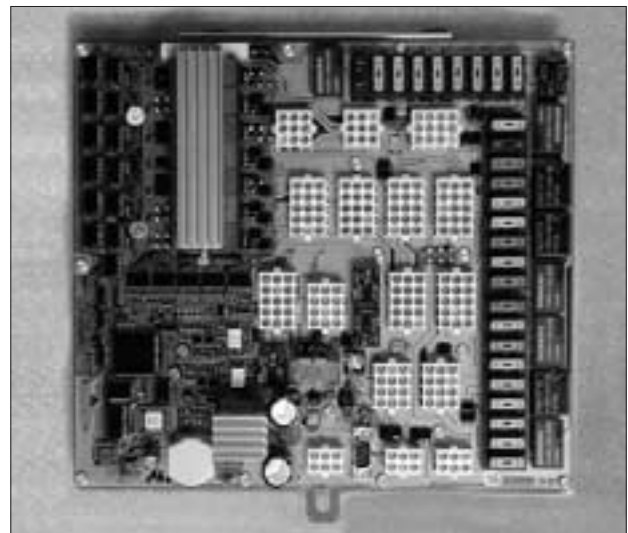

Corrosion Protection

Main components such as frame parts are passed through a shot blast process to remove any rust and slag deposits from the material surface before spray-painting. After this all parts, which have not been provided with special corrosion protection, are spray-painted in an automated spray-painting rail, which complies with the highest surface treatment and ecological requirements. The parts are first degreased, then phosphatised and dried. Afterwards the actual painting takes place using low-solvent High Solid paints, the priming and painting being executed wet on wet. As the name implies, these High Solid Paints have a very high content of solids, which makes them extremely resistant against impacts and corrosion. The engine hood and the cabin are made of PMMA plastic. All non-painted parts such as screws or hydraulic pipes are galvanised to improve their surface qualities and to ensure an effective protection against rust.



Certifications

The production facilities of the the new Volvo Compact Wheel Loaders have held the DIN EN ISO 9001 and DIN EN ISO 14001 quality and environmental management certificates for many years. Constant quality improvement and assurance is one of Volvo's key policies.



ZERTIFIKAT

Die TÜV CERT-Zertifizierungsstelle
der TÜV Rheinland
Anlagentechnik GmbH
bescheinigt gemäß
TÜV CERT-Verfahren, daß das Unternehmen

**Volvo Compact & Service
Equipment GmbH**
Max-Planck-Straße 1
D-54329 Konz

für den Geltungsbereich

**Design/Entwicklung, Produktion, Montage
und Kundendienst von Baumaschinen**

ein Qualitätsmanagementsystem eingeführt hat und anwendet.

Durch ein Audit, Berichts-Nr. 5128
wurde der Nachweis erbracht, daß die Forderungen der

DIN EN ISO 9001:1994
erfüllt sind.

Dieses Zertifikat ist gültig bis März 2001
Zertifikat-Registrier-Nr. 89 199 5128





Konz, den 21.07.1998
Zertifikat-Nr. 128



ZERTIFIKAT

Die TÜV CERT-Zertifizierungsstelle
des TÜV Saarland e.V.

bescheinigt gemäß TÜV CERT-Verfahren,
daß das Unternehmen

VOLVO
Compact & Service Equipment GmbH
D-54329 Konz-Könen

für den Geltungsbereich

**Design/Entwicklung, Produktion, Montage
und Kundendienst von Baumaschinen**

ein Umweltmanagementsystem eingeführt hat
und anwendet.

Durch ein Audit, Berichts-Nr. B 27478
wurde der Nachweis erbracht, daß die Forderungen der

DIN EN ISO 14001: 1996
erfüllt sind. Dieses Zertifikat ist gültig bis Juni 2000.
Zertifikat-Registrier-Nr. 71 104 7 002.





Sulzbach, 22.07.1998

Performance



Engine

The Volvo L30B and L35B Compact Wheel Loaders are powered by air/oil-cooled Deutz diesel engines from the 1011 series.

These modern turbo-charged engines have a low fuel consumption and an environmentally compatible exhaust gas ratio, which meets the requirements of the new ISO 8178 standard. Additional positive features of these engines are their low noise levels and the high performance reserves provided, which add to the long service life of the engines.

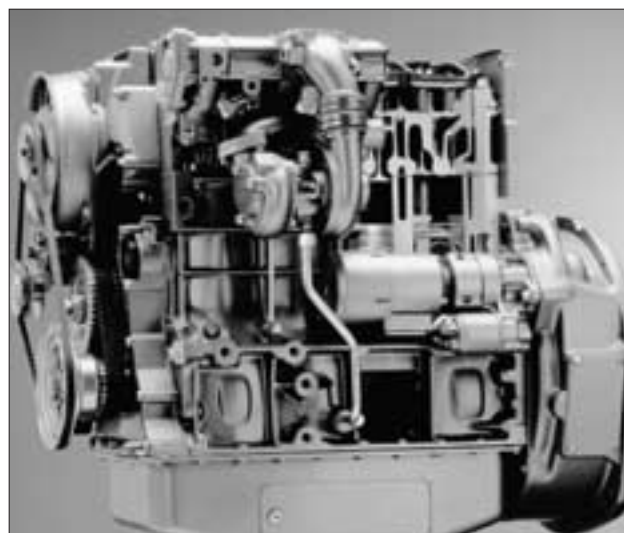
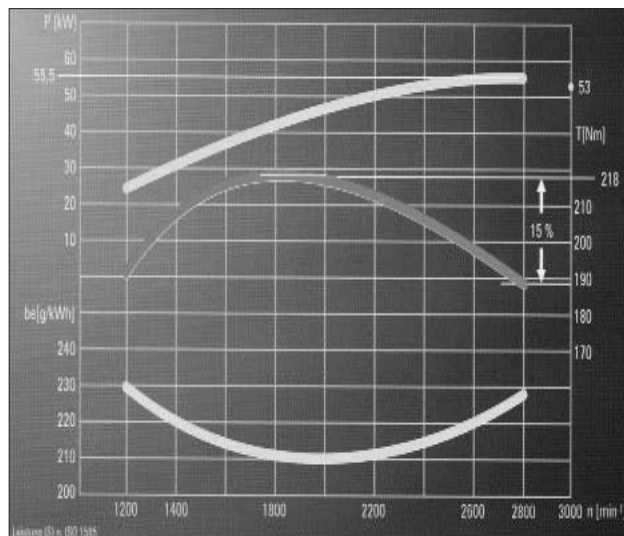

Drivetrain

The hydrostatic drive, which is perfectly tuned to the performance of the Deutz engines, is characterised by its high power and smooth adjustment. The automatic regulation of the hydrostatic drive ensures easy operation and maximum torque is available to the machine in all ranges, so that efficient operation is always possible.

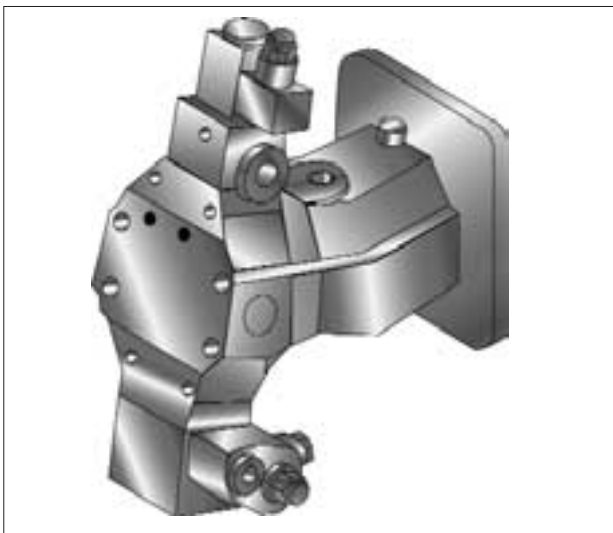
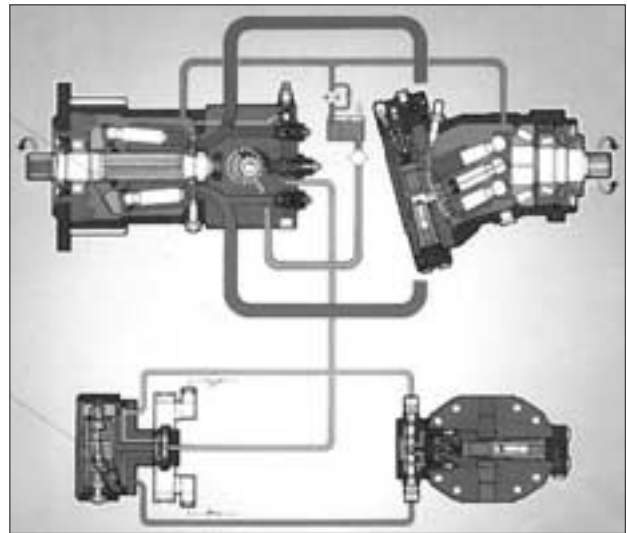

	Drawbar Pull (daN)/lbs	Pump	Engine
L30B Z	(4140)/9130	A4VG 56	A6VM 107
L30B Z/S	(3420)/7540	A4VG 56	A6VM 107
L35B Z	(4540)/10,010	A4VG 56	A6VM 107
L35B Z/S	(4350)/9590	A4VG 71	A6VM 140

Axles

Via the heavy duty portal axles supplied by ZF, the high drive torque is optimally transmitted to the wheels. The portal construction ensures an excellent ground clearance of the axles. A standard 100% differential lock can be engaged on both axles to ensure optimum traction, even on slippery surfaces. When driving on a solid surface the differential lock is disengaged to minimise tyre wear and to guarantee an optimum ground clearance, which is important for applications such as landscaping/agriculture or recycling.



Hydraulic System

The heavy-duty hydraulic system has two independent circuits for the working and steering hydraulics, each of which is supplied by its own pump. This makes mutual interference of working functions and steering movements impossible, and allows rapid operation. A high-capacity hydraulic oil cooler ensures good thermal conditions during operation and prevents the hydraulic system from overheating. This oil cooler is thermostatically controlled, so that the system rapidly reaches its operating temperature after a cold start. To operate hydraulic attachments such as a 4-in-1 bucket, an extra hydraulic circuit is provided as a standard. This extra circuit is activated by a separate control lever in the cabin, which can also be locked in the required operating position, for instance when working with a sweeper.

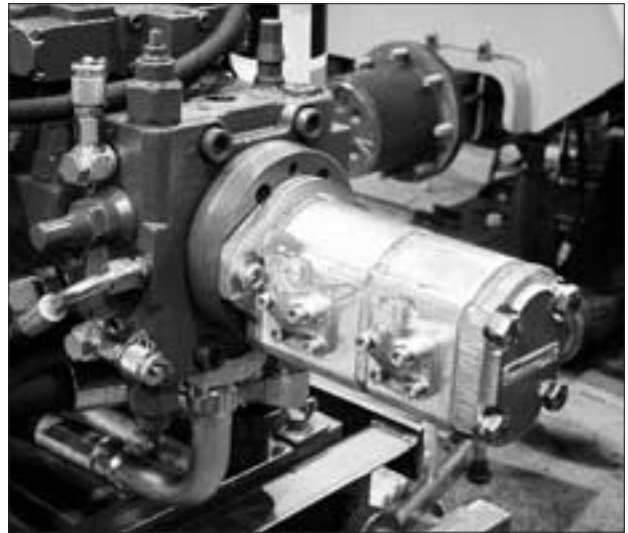

Linkage

The L30B and L35B have been fitted with a powerful Z-bar-linkage, which is distinguished by a high breaking and lifting performance and rapid loading cycles when working with buckets. A curved loading arm is of great advantage to ensure optimum lifting height and reach when loading truck with high side extensions. When used with the loading fork the Z-bar-linkage offers an excellent parallelism of the fork through the entire lifting range, allowing safe loading of pallets. A high roll-back angle of the loading fork lift allows the problem-free transport of loose goods, even when driving down grades.



Linkage

As a standard all Volvo Compact Wheel-Loaders feature a hydraulic attachment bracket, which is easy to operate and allows a good view to the change points. Allowing a smooth exchange of attachments within seconds without the driver having to leave the cabin.



Electrical System

All models in the B-series are equipped with an electronic service and information system, called ESIS. This involves a highly efficient monitoring and signalling system which has been used in larger construction machines for years. It continuously provides the driver with information on the operating condition of the machine and automatically signals possible malfunctions. Data on operating problems has been saved into ESIS, so that time can be saved when implementing the necessary adjustments. A programmable anti-theft system has been integrated into the electronic system and can be activated as required (optional).



Comfort



Spacious and Comfortable Operator Cabin

The spacious cabins of the Volvo Compact Wheel Loaders, identical on all L30B to L45B models, were developed in accordance with the latest ergonomic principles, focussing on the operator's comfort. The result is a successful combination of a functional design with simple and safe levers and controls, allowing efficient and comfortable operation. The single piece dashboard is clearly exposed to the operator. The levers and switches have been laid out ergonomically and are easy to operate. The low noise level inside the cabin contributes considerably to the operator's comfort.



Ergonomical Equipment

The operator's seat is multiply adjustable to allow comfortable seating positions to drivers of any sizes and to ensure fatigue-free work. The driving comfort is also enhanced by the adjustable steering column, and the individually adjustable control console with the height-adjustable arm rest. The driving pedals are laid out ergonomically and are easy to operate.



Excellent Allround View

The wide panorama windsshields with the narrow door posts allow the driver an excellent all-round view. Best in industry.



Powerful Blower and Extremely Efficient Climatization

A high-capacity three-phase heating fan provides the cabin with filtered outside air. Optimum heating and defrosting are ensured by a total of 7 adjustable fresh air blowers.

The sliding window incorporated in the left door (right optional) can be opened to provide extra fresh air.

A high-performance air-conditioning system is available upon request (optional).



Easy Access to Cabin

The built-in non-slip steps and the ergonomic handrails allow comfortable and safe access to the cabin from both sides of the machine.



Noise - Protected

The low noise level in the cabin adds considerably to the operator's comfort.

STANDARD VERSION		
	Inside Cab LpA	Outside Cab LwA
L30B Z	74 dB(A)	97 dB(A)
L30B ZS	72 dB(A)	100 dB(A)
L35B Z	78 dB(A)	101 dB(A)
L35B ZS	77 dB(A)	101 dB(A)

OPTIONAL LOW NOISE VERSION		
	Inside Cab LpA	Outside Cab LwA
L30B Z	-	-
L30B ZS	72 dB(A)	97 dB(A)
L35B Z	74 dB(A)	98 dB(A)
L35B ZS	74 dB(A)	98 dB(A)

Clearly arranged Dashboard

The clearly arranged dashboard keeps the operator informed about the operation status of the machine. Actuation of important functions such as lighting, rotating beacon or unlocking of attachment carrier is comfortably effected via the membrane key pad. To the left of the dashboard.



Safety



ROPS/FOPS Cabin

The safe and spacious cabins of the Volvo Compact Wheel Loaders were developed in accordance with the latest ergonomic principles to allow the driver fatigue-free and safe working. All cabins meet the strict safety requirements of the SAE standards for ROPS and FOPS, guaranteeing optimum safety for the driver in case of an eventual roll-over of the machine or objects falling onto the cabin roof.

The large, anti-skid steps and the ergonomic handrails allow comfortable and safe access from both sides of the machine.



Excellent Allround-View

The large, curved panorama windshields in combination with the slim door posts allow an excellent all-round view for the operator. The good front view onto the attachments and the quick coupler and the excellent rear view across the compact tail of the machine are essential contributions to safe operation.

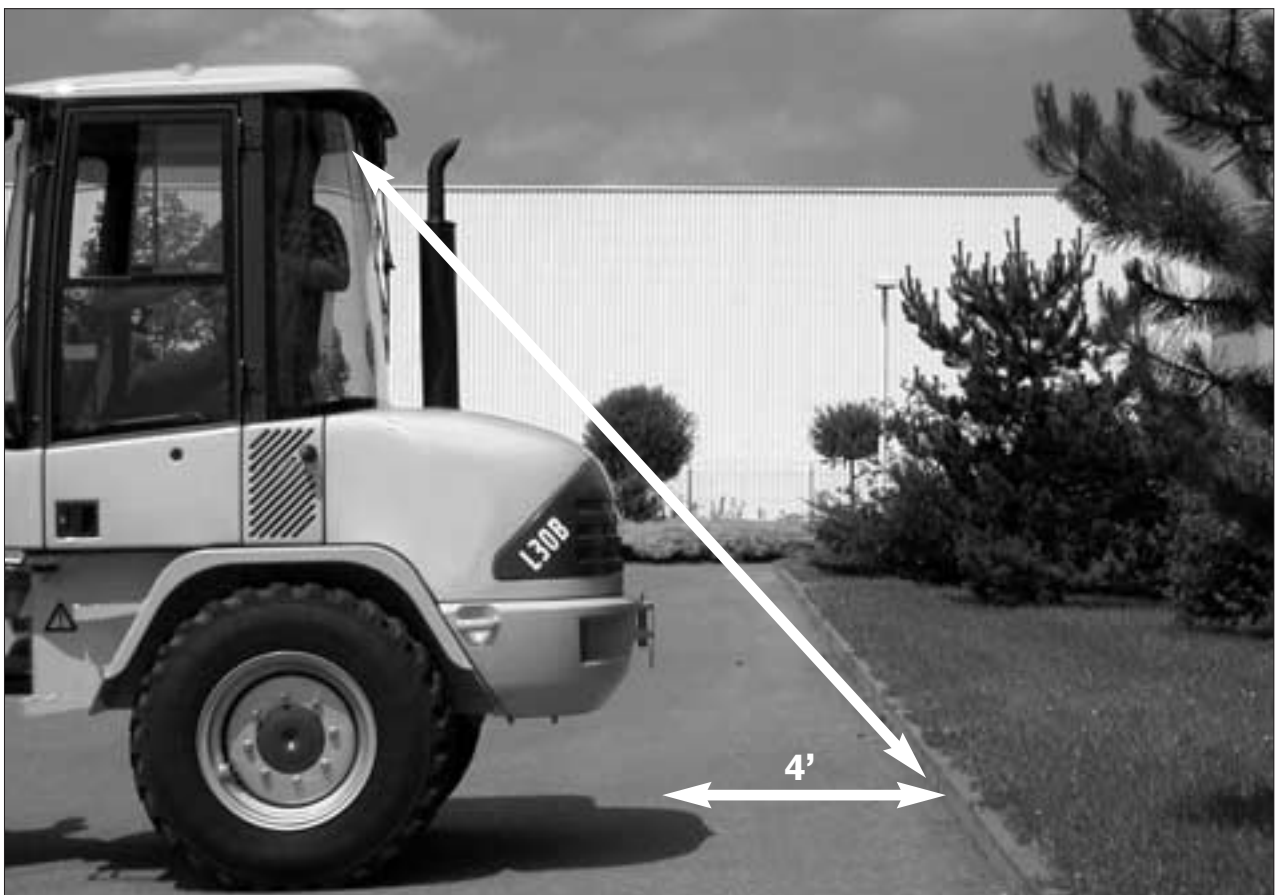

Lockable Hydraulic Functions

The multi-functional lever for servo-assisted controls allows selection of travel direction (forward/reverse), neutral position or differential lock without taking the hand from the lever. The conventional control lever (forward/reverse) on the steering column remains part of the standard equipment.

The membrane keypad allows all hydraulic machine functions to be blocked if required. This is important to increase the operational safety of the machine when driving on public roads.



Anti-Theft System

For increased anti-theft protection, an electronic immobilizer can be integrated into the ESIS system to be activated whenever required (optional).

The system can be ordered ex works or can be easily installed on any machine in the field.



Vandal Protection

To prevent unauthorised use and damage by vandals all controls, switches, electronic components etc. are housed inside the cab which can be locked when the wheel loader is not in use.



Vandal Protection

Similarly, certain critical components such as fuel and oil filler, batteries and maintenance points are housed under the lockable engine hood, so that they are well protected.



Safety Lamps and Warnings

The Compact Wheel Loaders L30B to L45B are equipped with standard working lights providing an adequate illumination for the front and rear operating field of the machine.

Rotating beacon and visual reverse alarm are available as an option. All wiring and switches for electrical options are preinstalled in the wiring system.



Safety during Maintenance

To prevent accidents the articulating-oscillating joint has always to be blocked with the blocking device provided when maintenance in the area of articulation is necessary.

The same is to be observed as regards usage of the support schock for maintenance works on inclined terrain.



Brake System

All Volvo Compact Wheel Loaders have dynamic hydrostatic brakes to bring the machine to a full standstill during normal operation. In addition the L30B and L35B have high-performance combined operating and parking brakes. These low-maintenance drum brakes are mounted to the centre of the rear axle drop box acting on all 4 wheels through the cardan shaft. In the 19 mph models the service brake is a dry disc brake located centrally on the front axle, which provides the braking force required for these high-speed versions; as in the 12.4 mph models the parking brake is a drum brake on the rear axle.

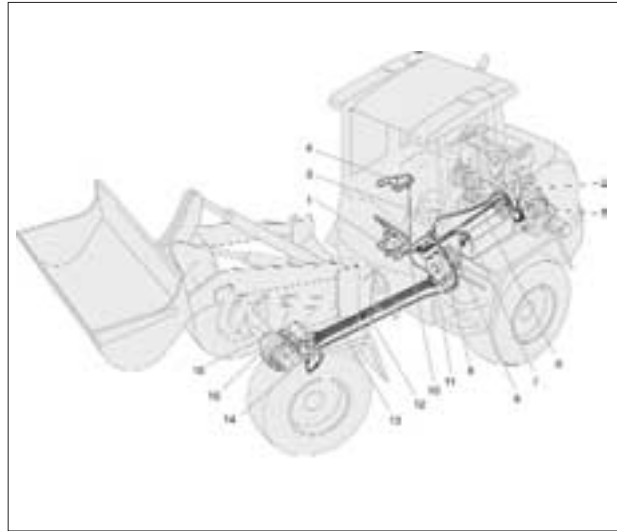

Service



Easy Access to Service Points

The maintenance intervals of the Deutz 1011 engines are extremely long 500 hrs. The cost of repair are minimised by the use of individually exchangeable injection pumps. The air/oil cooling system does not require any maintenance, except for the scheduled check of the oil cooler for contamination.



Important Service Points

The transverse mounted diesel engine makes the maintenance and service points easily accessible. The main elements such as the dipstick, oil filter, fuel filter and water separator have been arranged carefully. Other elements requiring maintenance such as air filters, hydr, filters or hydraulic tank level indicators are also located under the engine hood, where they are easily accessible.



Fuel-Tank Filler

The filler neck for hydraulic oil and fuel are also located under the engine hood, which is designed so that no extra adapters are necessary to top up oil or fuel from cans, as often happens on construction sites.



Hydraulic System

The hydraulic reservoir of the Volvo Compact Wheel Loaders supplies oil to the drive system, the working and steering hydraulics. The central tank is fitted with a combined suction and return filter, which can be changed without draining the tank. The hydraulic oil fillers and oil level indicators are easily accessible. Minimes couplers in the drive, work and steering hydraulics allow the hydraulic pressure to be checked if necessary.



Easy Access to Lubrication Points

The maintenance of the machine is facilitated by easily accessible grease nipples. The number of grease points has been held as low as possible. The grease gun, necessary for lubrication purposes, has its fixed place in the engine compartment.



Electrical System

The electronic service and information system, ESIS, supports the maintenance of the machine by displaying specific information and error codes in the display on the instrument panel. The central computer is built onto a well-organised circuit board which is placed well protected, yet easily accessible in the cabin. The electrical wires have alphanumeric markings in accordance with the Volvo standard to facilitate possible troubleshooting. Housed together the battery main switch and the battery are located at an easily accessible position under the engine hood.



Single - Key Locking

Operators and service staff working on an L30B/L35B Volvo Compact Wheel Loader need one key only. It fits on all locks on the machine, such as the locks on both access doors, the ignition switch, the storage box and the engine hood.



Options/Versatility

The Volvo Compact Wheel Loaders can be fitted with a wide range of attachments to turn them into versatile all-rounders. The hydraulic attachment bracket device allows the driver to change from a bucket to a material handling arm or to attach a loading fork in seconds - comfortably from the driver's seat, without having to leave his cab. In addition, a wide range of useful extra or special equipment such as boom arm suspension system, additional hydraulic circuits or an air-suspension operators seat are available to allow the driver to work in a comfortably environment.



Attachments

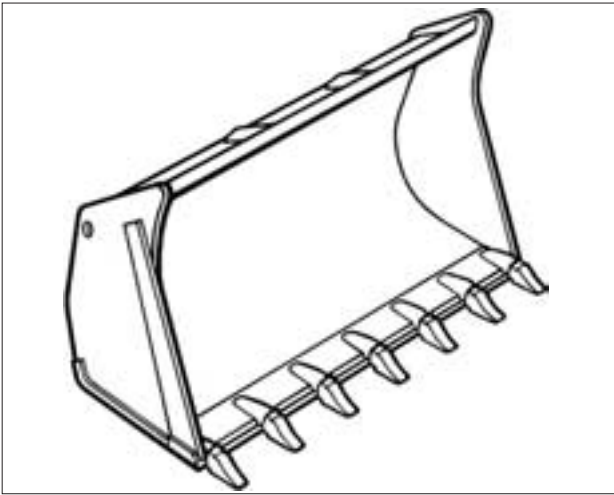

Standard Bucket with Teeth

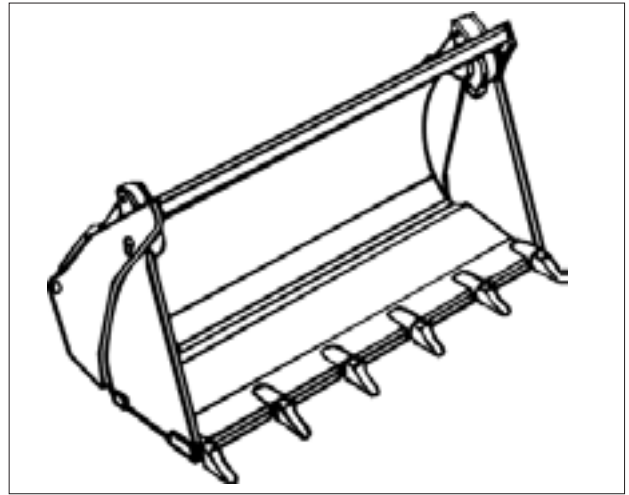

4-in-1-Bucket

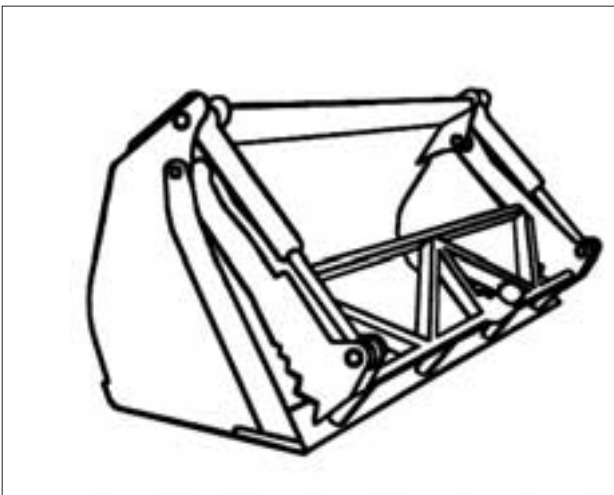

Bucket with Hydraulic Grapple

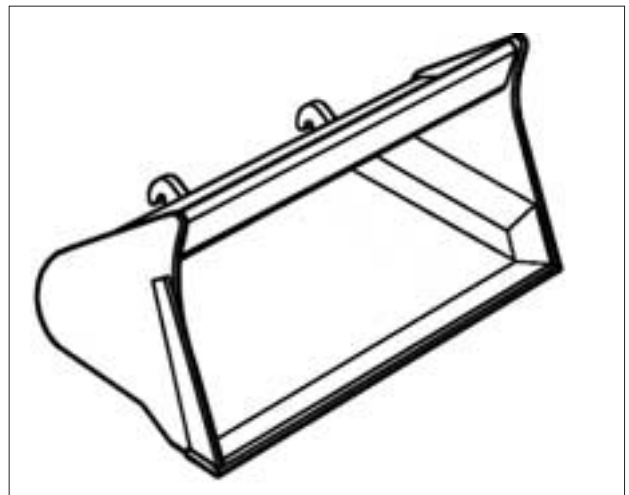

High-Tip-Bucket

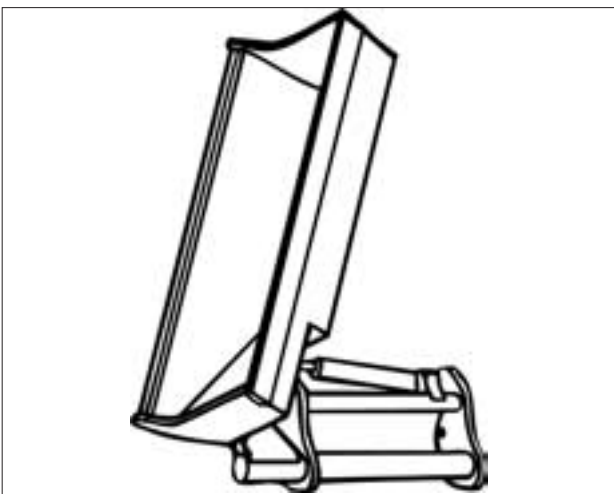

Side-Tip-Bucket

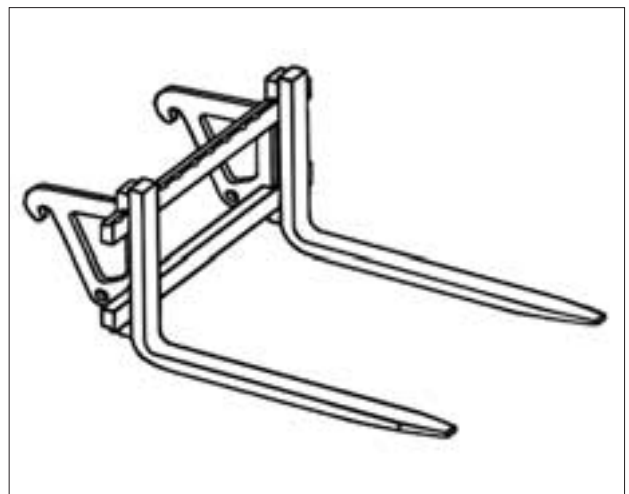

Loading Fork

Hydraulic Equipment



4th Circuit



Hand Control Inch Valve

Please check market related standard for your country

Linkage System



Tilt Cylinder Dump Control Valve
to be used with buckets with grapples



Safety Valve for Lift Cylinders



Boom Kickout



Automatic Bucket Leveller

Engine Equipment



Oilbath Aircleaner



Particle Filter



Cooling Air Filtration Screen (2,5 mm)



Turbo II Pre-Filter

Cab Equipment



12 Volt Radio/Cassette



Handthrottle



Air Suspension Operators Seat

Electrical System



Rotating Beacon



Accessories Power Socket (Standard USA)



Working Lights



Visual / Audible Reverse Alarm



Additional Working Light



Front Electrical Socket

Carriage Body



Front fender



Mudflaps, Front

Attachment Bracket



Attachment Bracket, Volvo-System
(Standard USA)

Tires



MICHELIN



Under our policy of continuous product improvement, we reserve the right to change specifications and design without prior notice, The illustrations do not necessarily show the standard version of the machine.

VOLVO

**Volvo Construction Equipment
North America Inc.**

One Volvo Drive, Asheville, N.C. 28803-3447

Tel: 828-650-2070, Fax:828-650-2508

Ref. No. 22 1 430 5532
Printed in USA 2000.07
Biltmore Press, Asheville

USA/English
CWL